



Nationwide supplier of trims, mouldings and components for the glass and mirror industry.

PanelGrip™ Dry Glaze Glass Railing System

Patent Pending

- **Reduces Labor Costs up to 80%**
- **Reduces Freight Costs up to 30%**
- **Broadest Grip Range of any Dry Glaze Option**
- **No Special Tools Required**
- **No Mess**



*You will never think of
Glass Railing the same way again!*



www.morseindustries.com

1-800-325-7513

You can rely on Morse Industries to provide the products you need, on time and as promised. Our employees consult with you one-on-one to make sure you get what you need. Let Morse Industries help make your next project a success.

PANELGRIP™ DRY GLAZE SYSTEM - Patent Pending

The latest development in Glass Railing technology, PanelGrip™ facilitates the quick assembly of structural glass railing without messy fillers or special tools with significant savings in labor and shipping costs.

**Easy to
Install**

- 1. Place Plastic Isolator into Shoe**
- 2. Insert Glass**
- 3. Insert PanelGrip™ on Opposing Side**
- 4. Tighten Screw with Allen Wrench**
- 5. Done!**

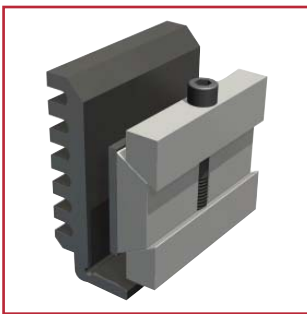

A42-0011
Panel Grip™ Locking Mechanism
Patent Pending



A42-0074 & A42-0075
Panel Grip™ Base Shoes
Patent Pending

Reduce Labor Costs up to 80%

No sealing of shoe, no setting blocks, no plumbing of glass, no multiple pours of cement, no waiting for cement to cure, no messy clean-up.

Reduce Freight Costs up to 30%

PanelGrip™ base shoe is 30% lighter than standard base shoes yet meets structural load requirements for railings.

Broadest Grip Range Of Any Dry Glaze Option

Made for nominal 1/2" (12.7mm) tempered glass but will work for any panel between .450" and .515" (11.5mm and 13mm).

No Special Tools Required

All you need is an Allen wrench for installation or removal.

No Mess

No mixing and pouring of expansion cement, no running of cement on incline.

PANELGRIP™ DRY GLAZE SYSTEM - Patent Pending

Aluminum Base Shoe

PanelGrip Base Shoe is extruded from 6063-T5 in mill finish (other lengths available upon request).

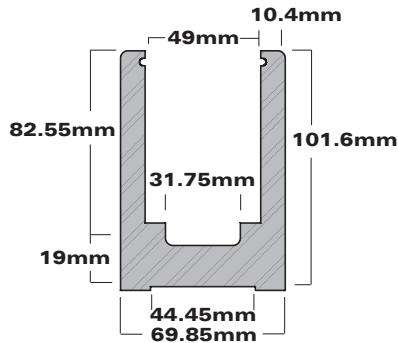

A42-0074
Stocked in:
 3m & 6m lengths -
 Counter Bore,
 Counter Sunk & Undrilled
 For use with 19mm glass

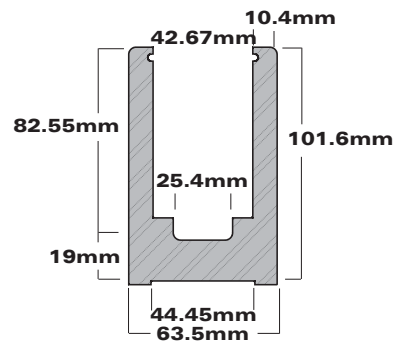

A42-0075
Stocked in:
 3m & 6m lengths -
 Counter Bore,
 Counter Sunk & Undrilled
 For use with 12.7mm glass

Screws & Bolts

Part#	Description	Measurement
F92-0075FH	Stainless Steel Flat Head Screws (10 per pkg)	12.7mm - 13 x 31.75mm
F92-0075WB	Zinc Plated Wedge-Bolt® - Orange Tip (10 per pkg)	9.5mm x 101.6mm



Aluminum Base Drain Block

Placed under exterior installed base shoes to provide drainage space for water runoff. Great for balconies and decks. 10 blocks per package.

Part#	Measurement
A42-0013-10	57.15mm x 63.5mm x 9.5mm

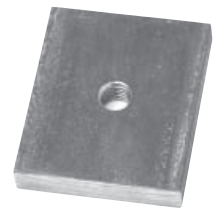

Plumbing Bar Kit

Plumbing bar kit includes plumbing bar and one panel grip.

1. Place isolator in shoe, insert plumbing bar on top of the isolator and lock into place with a PanelGrip.
2. Shim as needed until a level indicates vertical plumb.
3. Remove plumbing bar and repeat as needed.



A42-0021

PANELGRIP™ DRY GLAZE SYSTEM - Patent Pending

Cladding

Stainless Steel

.035 guage/thickness, #8 polished or #4 brushed finishes are standard.

Part#	A	B	Length	Base Section
S16-0075	20.6mm	101.6mm	3m, 3.6m	A42-0075
S16-0074	20.6mm	101.6mm	3m, 3.6m	A42-0074

Brass (or Muntz)

.050 guage/thickness, #8 polished or #4 brushed finishes are standard.

Part#	A	B	Length	Base Section
B11-0075	20.6mm	101.6mm	3m, 3.6m	A42-0075
B11-0074	20.6mm	101.6mm	3m, 3.6m	A42-0074

Aluminum

.050 guage/thickness, available in clear satin and dark bronze.

Part#	A	B	Length	Base Section
A16-0075	20.6mm	101.6mm	3m, 3.6m	A42-0075
A16-0074	20.6mm	101.6mm	3m, 3.6m	A42-0074

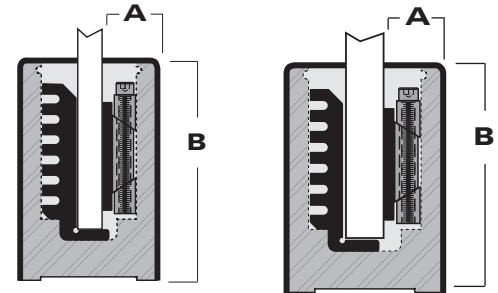

S16-0075
B11-0075
A16-0075

S16-0074
B11-0074
A16-0074

End Caps

Stainless Steel End Caps

.035 guage/thickness, #8 polished or #4 brushed finishes are standard.

Part#	Base Section Part #
S17-0074	A42-0074
S17-0075	A42-0075

Brass (or Muntz) End Caps

.050 guage/thickness, #8 polished or #4 brushed finishes are standard.

Part#	Base Section Part #
B12-0074	A42-0074
B12-0075	A42-0075

Aluminum End Caps

Aluminum end caps are oversized for easy finishing. .050 guage/thickness, available in mill finish, clear satin and dark bronze.

Part#	Base Section Part #
A17-0074	A42-0074
A17-0075	A42-0075



Recommended Cladding Attachment Options

Take care to properly align cladding before pressing into place.

1. Apply two rows of tape to the vertical face of the cladding and apply a silicone bead between the rows.
2. Apply three rows of tape to the vertical face of the cladding.
3. Apply silicone to the vertical face of the cladding. Use clamps to hold the cladding in place until the silicone cures.

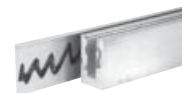
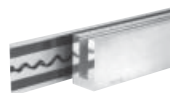

PANELGRIP™ DRY GLAZE SYSTEM - Patent Pending

Panel Grip™ Isolator

The patented PanelGrip™ System utilizes a unique locking mechanism of high-strength aluminum and PVC isolators combined with a specially designed aluminum shoe moulding. Isolator assembly is adjustable to accommodate both 12.7mm and 19mm glass. The PanelGrip System was tested per ASTM E935 Standard Test Methods for Performance of Permanent Railing Systems and Rails for Buildings. This test report can be requested by calling customer service at 1-800-325-7513.

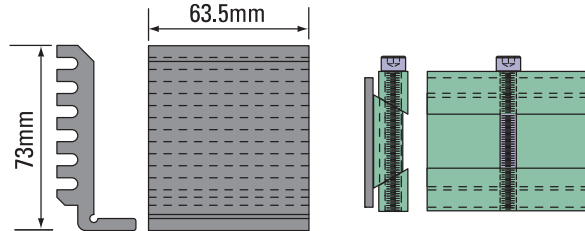

Part#	Description
A42-0011-4	Package of Four
A42-0011-1	Single Unit

PANELGRIP™ SPACING GUIDELINES

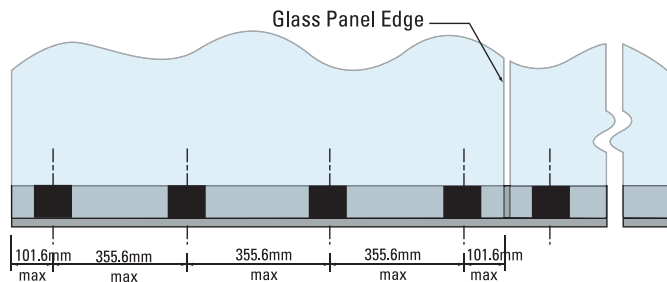

System for 90 kg point load with 4 × safety factor
 355.6mm center-to-center maximum with
 101.6mm maximum from center to glass edge.

Rubber Base Shoe Gaskets

For use without cladding. Seals the gap at top of base shoe. Sold by the foot.

Part#	Width	Height
V50-0003	19mm	14.3mm



V50-0003

For use with cladding. Set cladding into place on base shoe, then press into place between glass and cladding. Sold by the foot.

Part#	Width	Height
V50-0004	12.7mm	11.1mm



V50-0004

For use with cladding only. Peel back paper to reveal self adhesive strip. Adhere to underside of cladding before applying cladding to base shoe. Sold by the foot.

Part#	Width	Height
V50-0005	28.5mm	6.35mm

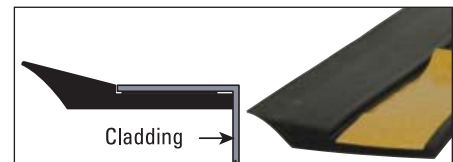

V50-0005

PANELGRIP™ DRY GLAZE SYSTEM - Patent Pending

The **PanelGrip™** System utilizes a unique locking mechanism of high-strength aluminum and PVC isolators combined with a specially designed aluminum shoe moulding. When assembled with 12.7mm or 19mm tempered glass, **PanelGrip™** enables the installer to fabricate a structural **glass railing system** with significant reductions in labor and freight costs.

PANELGRIP™ INSTALLATION:

1. PLUMBING PANELGRIP™ SHOE MOULDING

Before completing attachment of **PanelGrip™ Shoe Moulding** to substrate – in multi-panel railings – take all necessary steps to assure that the mounted shoe is adjusted such that the inside channel of the shoe it is plumb to +/- 3.175mm at an extended height of 106.6cm. Spend the time required to plumb the shoe to this tolerance since **the glass will only be as plumb as the shoe**. One method for plumbing the shoe is the **Plumbing Bar Kit**.

2. CLEAR THE PANELGRIP™ BASE SHOE OF ALL DEBRIS.

3. PLACE ISOLATORS

Place the **PanelGrip™ Plastic Isolators** into the **Shoe Moulding**. Space **Plastic Isolators** a maximum of 355.6mm on center with a maximum of 101.6mm in from the left and right edges of each panel – 4 isolators per 4 foot panel.

4. PLACE GLASS

Place the glass atop the **Plastic Isolators** in the **Shoe Moulding**. **PanelGrip™** will work with nominal 12.7mm and 19mm glass.

Warning: With multi-panel railings, do not line up the edge of a panel with the end of the shoe – place the panels so that they Span **PanelGrip™ Shoe Moulding** butt joints to assist in alignment.

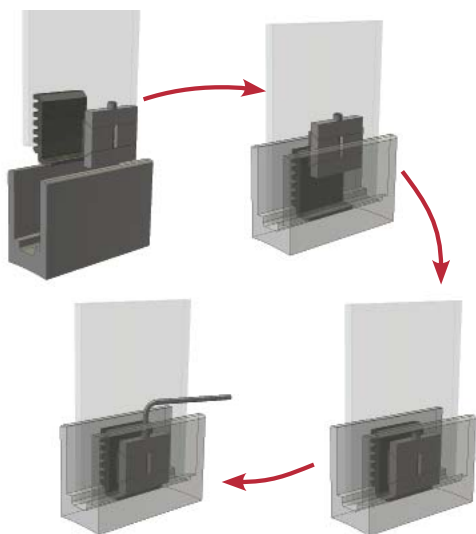

5. INSERT PANELGRIP

Have someone hold the panel in place while you insert the aluminum **PanelGrip™** mechanism into place on the opposite side of the glass in alignment with the **Plastic Isolators**. Make sure that the black, plastic pad on the **PanelGrip™** is facing the glass.

6. TIGHTEN PANELGRIP

Using the 4.76mm hex head wrench provided, tighten the cap screw on the **PanelGrip™** mechanism. While tightening, the plastic pad will break away from the aluminum as the unit expands.

7. CONFIRM ALIGNMENT AND TIGHTEN

Confirm alignment and make adjustments prior to final tightening which will compress and lock the panel into place. Remember, **PanelGrip™** is self-centering and self-plumbing. Make sure you have properly plumbed the shoe as noted in Step 1.

Once you have confirmed position, use the 4.76mm hex head wrench to make the **PanelGrip™ Cap Screw** snug-tight, then continue tightening for one quarter turn – 3-4.5m/kg of torque. Repeat on all other **PanelGrip™** units to secure the panel in position.

8. SEAL TOP OF SHOE

Once glass is properly positioned, seal gap at the top of the **PanelGrip™ Shoe Moulding** using one of the three **Gasket** styles noted below. Spray glass cleaner onto glass to facilitate insertion of gaskets.

- **V50-0003** is used without cladding
- **V50-0004** is inserted between cladding and glass
- **V50-0005** is taped to the underside of the top lip of the cladding.

9. REMOVAL OF GLASS

Should you need to remove a panel, this can be done simply by loosening the **PanelGrip™ Cap Screw**.

Note: The Cap Screw included in the **PanelGrip™** contains a pressure-sensitive locking compound that insures the screw remains tight over time and through cyclic loading. Each insertion and removal cycle diminishes its locking capacity. Individual results will vary but four cycles is the typical life span of the compound.